



## RDG260KN RDG264KN



User manual, documentation  
and parameters  
[sid.siemens.com/home](http://sid.siemens.com/home)



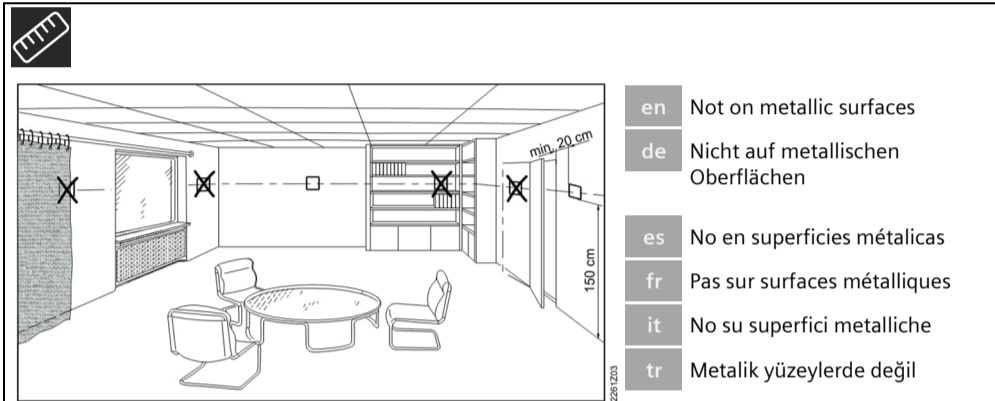
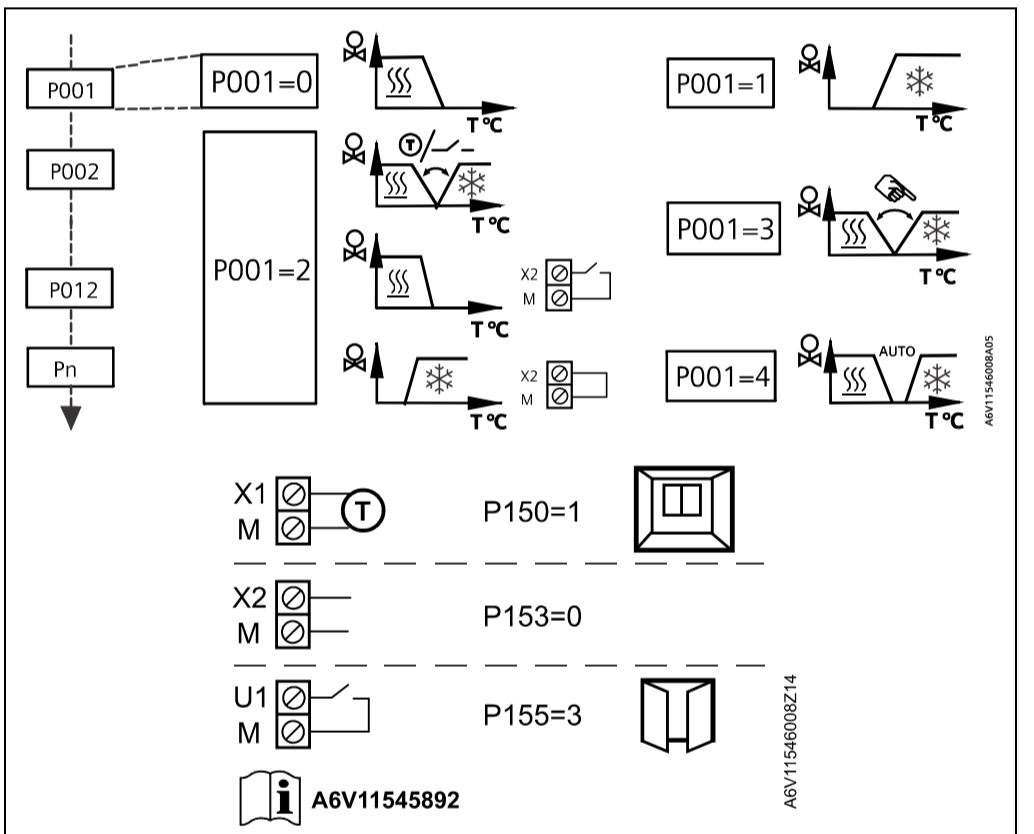
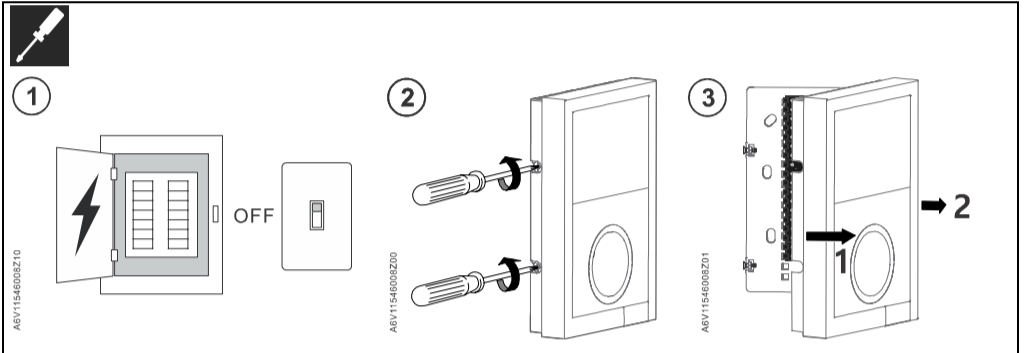
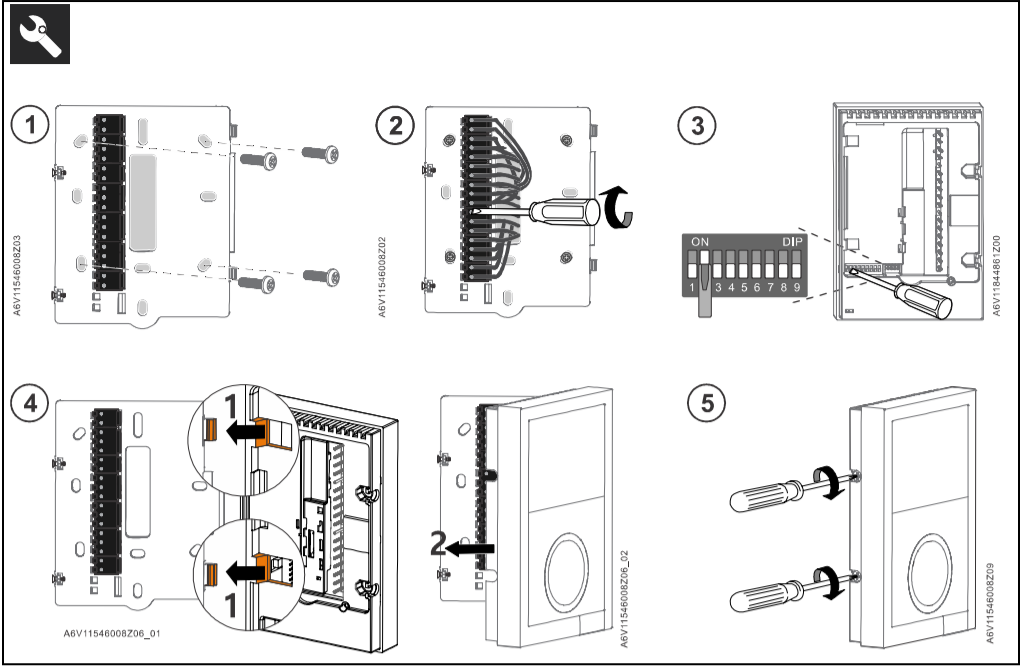

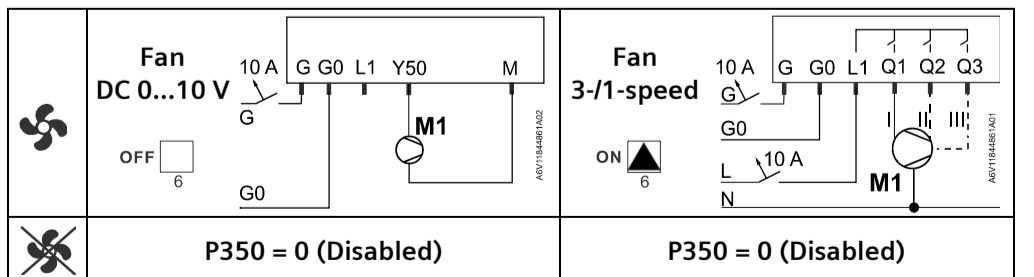
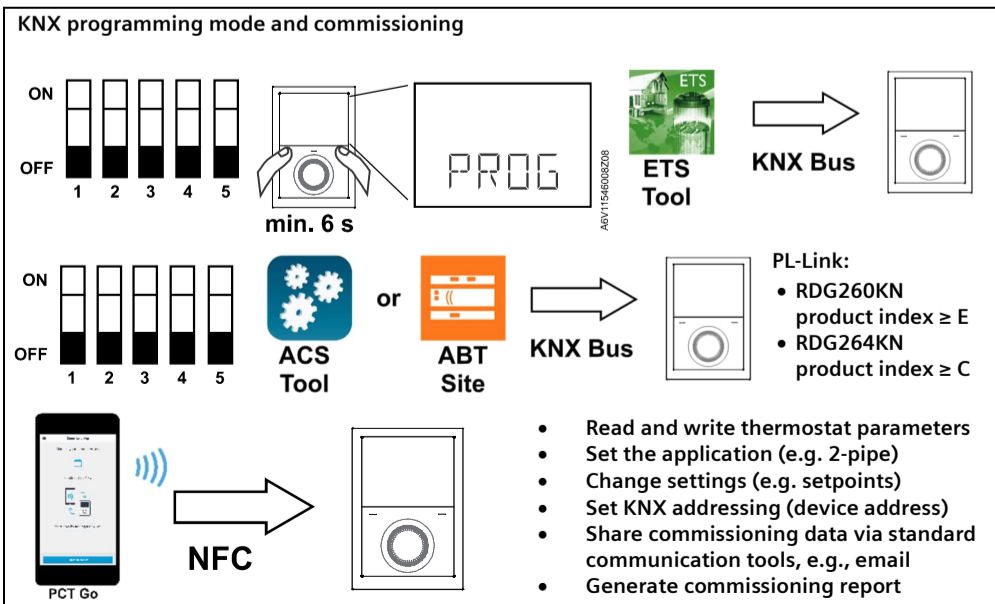
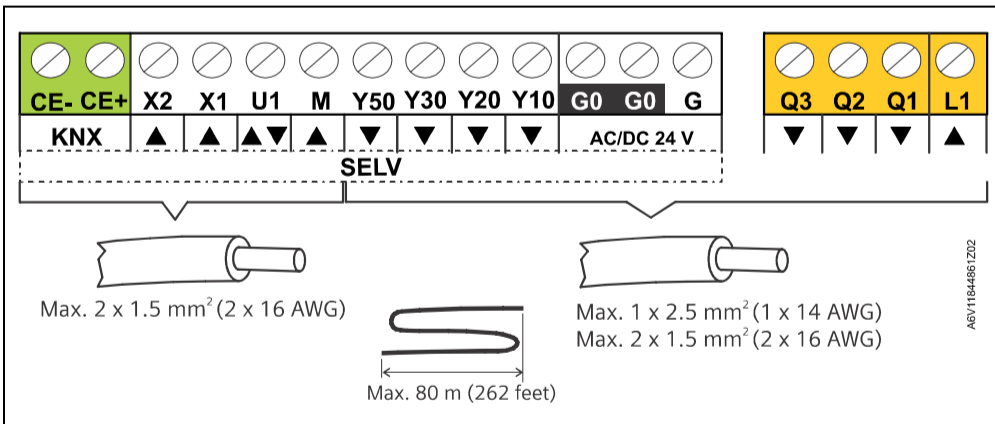
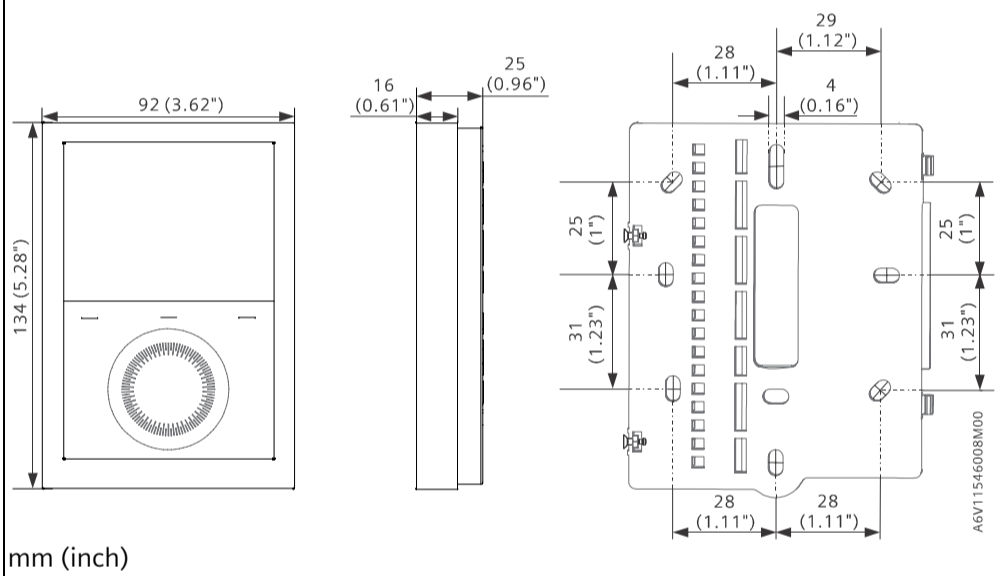

- |    |                         |    |                         |    |                          |
|----|-------------------------|----|-------------------------|----|--------------------------|
| en | Mounting instructions   | de | Montageanleitung        | es | Instrucciones de montaje |
| fr | Instructions de montage | it | Istruzioni di montaggio | tr | Montaj talimatları       |

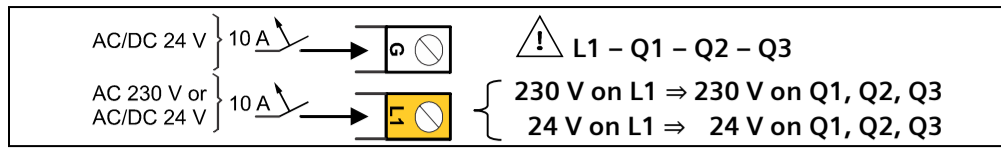

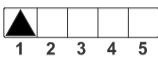











































- |    |                                    |
|----|------------------------------------|
| en | Not on metallic surfaces           |
| de | Nicht auf metallischen Oberflächen |
| es | No en superficies metálicas        |
| fr | Pas sur surfaces métalliques       |
| it | No su superfici metalliche         |
| tr | Metalik yüzeylerde değil           |











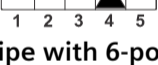



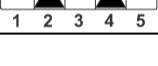





Application	V1	Outputs	
① 2-pipe 		DC  V1 3-speed 	On/Off  V1 3-speed 

Application	V1	V2	Outputs			
② 2-pipe with electric heater 			DC DC  V1  V2 3-speed 	On/Off On/Off  V1  V2 3-speed 	DC On/Off  V1  V2 3-speed 	On/Off DC  V1  V2 3-speed 
③ 2-pipe with radiator 						
④ 4-pipe 						
⑤ 2-pipe/2-stage 						

Application	V1	V2	V3	V4	Outputs			
⑥ 4-pipe with electric heater 				-	⑥ <input checked="" type="checkbox"/>	DC DC DC DC  V1  V2  V3  V4 3-speed 	⑥ <input checked="" type="checkbox"/>	DC DC On/Off  V1  V2  V3 3-speed 
⑦ 4-pipe/2-stage 					⑦ <input checked="" type="checkbox"/>	DC 3-speed 	⑦ <input checked="" type="checkbox"/>	DC 3-speed 

Application	V1	V2	Outputs	
⑧ 4-pipe with 6-port ball valve 		-	⑧ <input checked="" type="checkbox"/>	DC (PICV) On/Off  V1  V2 3-speed 
⑩ 4-pipe with 6-port PICV 		-	⑩ <input checked="" type="checkbox"/>	DC (PICV) On/Off  V1  V2 3-speed 
⑨ 4-pipe with 6-port ball valve as changeover and PICV 			⑨ <input checked="" type="checkbox"/>	DC (PICV) On/Off  V1  V2 3-speed 

IAQ/CO <sub>2</sub>	Limits:	
	DC	3-speed
On/Off	Q3	U1 (*) U1 (*)

(\*):  Appl. ⑦ does not support.

	en	de	es	fr	it	tr
①	2-pipe fan coil	2-Rohr Ventilator-konvektor	Fancoil a dos tubos	Ventiloconvecteur 2 tubes	Fan coil 2 tubi	2 borulu fan coil
②	2-pipe with electric heater	2-Rohranwendung & Elektroheizung	2 tubos & batería eléctrica	Application 2 tubes & batterie électrique	Fan coil 2 tubi con batteria elettrica	2 borulu & elk. ısıtıcı
③	2-pipe with radiator	2-Rohranwendung & Radiator	2 tubos & radiador	Application 2 tubes & radiateur	Fan coil 2 tubi e radiatore	2 borulu & radyatör
④	4-pipe fan coil	4-Rohr Ventilator-konvektor	Fancoil a 4 tubos	Ventiloconvecteur 4 tubes	Fan coil 4 tubi	4 borulu fan coil
⑤	2-pipe/2-stage	2-Rohr/2-stufig	2 tubos/2 etapas	2 tubes/2 étages	2-tubi / 2-stadi	2-borulu/2-kademe
⑥	4-pipe with electric heater	4-Rohranwendung & Elektroheizung	4 tubos & batería eléctrica	Application 4 tubes & batterie électrique	Fan coil 4 tubi con batteria elettrica	4 borulu fan coil & elk. ısıtıcı
⑦	4-pipe/2-stage	4-Rohr/2-stufig	4 tubos/2 etapas	4 tubes/2 étages	4-tubi / 2-stadi	4-borulu/2-kademe
⑧	4-pipe with 6-port ball valve	4-Rohr mit 6-Weg-Kugelventil	4 tubos con válvula de bola de 6 vías	4 tubes avec vanne à boisseau sphérique 6 voies	4-tubi con valvola a 6 vie	4-borulu, 6-yollu küresel vana
⑨	4-pipe with 6-port ball valve as changeover and PICV	4-Rohr mit 6-Weg-Kugelventil für Umschaltung und PICV	4 tubos con válvula de bola de 6 vías como cambio y PICV	4 tubes avec vanne à boisseau sphérique 6 voies comme changeover et PICV	4-tubi con valvola a 6 vie per commutazione stagionale e valvola PICV	4-borulu, PICV ve yaz kış geçişi için 6-yollu küresel vana
⑩	4-pipe with 6-port PICV	4-Rohr mit 6-Weg-PICV	4 tuberías con PICV de 6 puertos	4 tubes avec (vanne) PICV 6 voies	4-tubi con valvola a 6 vie PICV	4-Borulu 6-Yollu PICV vana